

Note: Isometric drawing is for reference only, details may not accurately represent actual design - please see detailed views for technical information

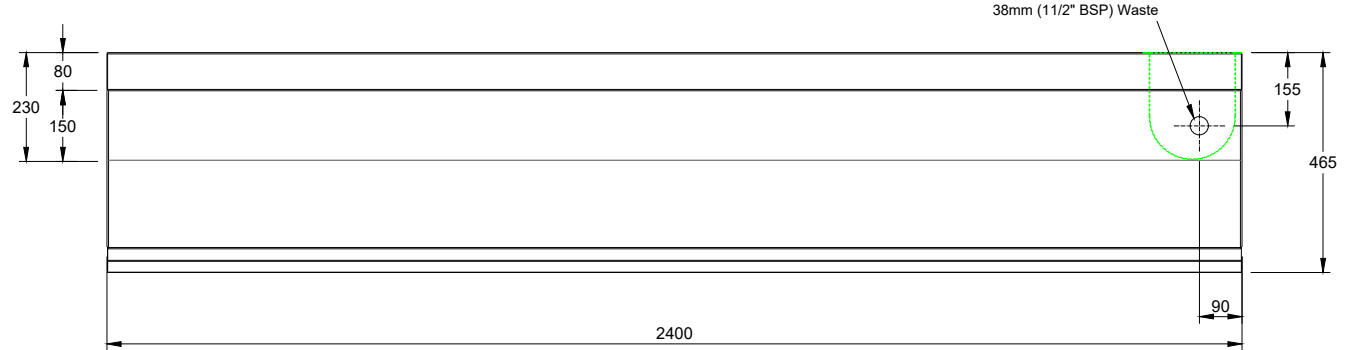

Note
2 Tapholes or 1 Taphole arrangement available.
Additional sensor hole can be supplied at no extra cost when specified at time of ordering.

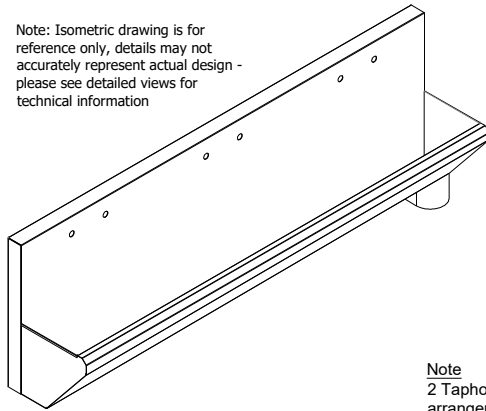
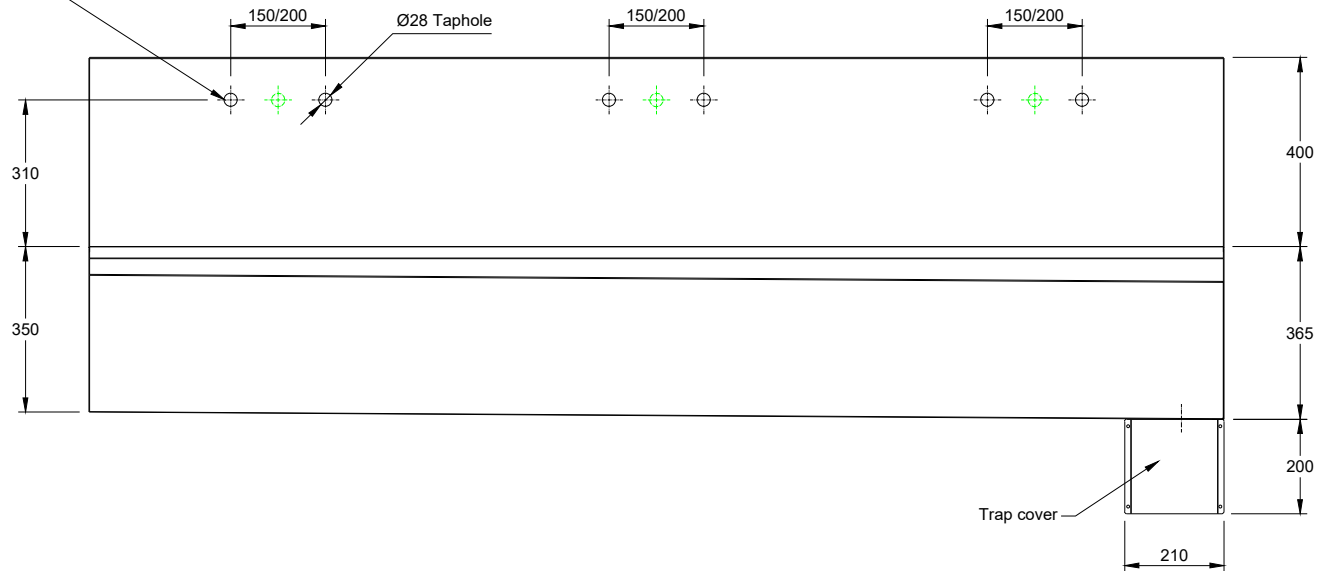
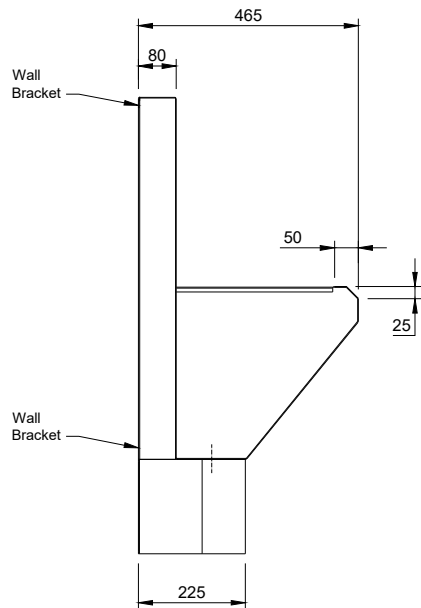

DO NOT SCALE DRAWING

A	27/06/2019	Design modified
---	------------	-----------------

TITLE: 3 User 2400mm Surgeons Scrub Trough Sink - HBN 00-10 & HTM 64 - High-Back, RH			
WEIGHT: Trough: 55.80kg & Trap Cover: 1.31kg	PRODUCT CODE: HL4124R		
MATERIAL: 1.5mm thick grade 1.430 (304) Stainless Steel in a satin finish	SCALE: NTS	PAPER: A4	DATE: 03/06/2019

NOTES:
Drawing to: BS8888 Engineering Drawing Practice
Welding to: BS EN 25817:1992 Quality Level B
Tolerance unless otherwise stated to be:
Machining: $\pm 0.75\text{mm}$. Centre distance $\pm 0.25\text{mm}$. Angles $\pm 0.30\text{mm}$
Fabrication: Up to 600mm $\pm 0.75\text{mm}$ Over 600mm $\pm 1.5\text{mm}$. Angles $\pm 1\text{mm}$.
Screw threads to BSI Medium Fit
Remove all burrs and sharp edges

HEALEY & LORD
A MAG Group Company

Website: www.hlwashrooms.co.uk
Tel: 01603 558855
Email: sales@hlwashrooms.co.uk
Address: HL Washrooms, MAG Building,
Vulcan Road South, Norwich, Norfolk, NR6 6AF